

SHARP

MX-C300W / MX-C250F
Digital Full Colour Multifunctional System

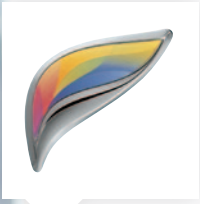

DESKTOP MFP WITH COMPACT
AND SMART DESIGN

You strive for efficiency. You hate waste /**This is Why** you'll love these desktop MFPs.

Powerful, compact and affordable /This is Why these MFPs are right for you.

The more successful you are, the more there is to do. And, somehow, there never seems to be enough time, money, people or space. Which is why, if you're looking for a new multifunction printer (MFP) you should take a close look at the Sharp MX-C300W or MX-C250F.

The two models are capable of printing and copying at speeds of either 30 or 25 pages per minute (ppm). And that's regardless of whether you're working with black & white or full colour documents. That's plenty of performance for any small workgroup and more than enough for personal use.

But print speeds are just one part of the productivity equation. That's why we've designed these MFPs to print and copy on both sides of the page automatically, saving you time and effort while reducing paper consumption.

A 50-sheet document feeder (35-sheet if you choose the MX-C250F) lets you scan as many as 9 full colour pages every minute at the full 600 x 600 dpi resolution. Just load your documents and let the MFP do its job while you get on with something else.

Fits where you want, does what you need

These MFPs are a great choice if you're short on space. Not only do they have a surprisingly compact design but you can increase the paper supply right the way up to 800 sheets without using more desk space.

Both models are equipped with a handy USB port for walk-up printing and scanning with a memory stick. And if you choose the MX-C300W, you can connect it to a wireless network and print wirelessly from your smartphone or tablet.



FRONT ACCESS USB PORT



CHOICE OF DOCUMENT FEEDERS

Resources are precious /This is Why we help you make the most of them.

The MX-C300W and MX-C250F are small in size and smart in design. Both come with an easy-to-read LCD control panel with programmable function keys, and their two-component development system delivers quality that's sure to impress.

Other useful features include full fax functionality (with PC-Fax and inbound routing for emailing faxes to their correct destination) and ID Card Copy.

ID Card Copy makes it easy to copy both sides of a card (such as an ID card or credit card, for example) on to a single page. It's convenient, and it saves you money.

Built-in security

If you're in a shared office you might want to control who can use your MFP. And you certainly don't want sensitive documents being left out in the open.

With User Authentication, we help you restrict access to authorised users who can 'unlock' the device by identifying themselves with a personal 5-digit security code.

For extra peace of mind, Sharp uses IPsec technology to encrypt data and to make sure that your system isn't communicating with any unidentified users.

Energy Efficiency

No one likes to waste energy. And that's another reason to put the Energy Star-certified MX-C300W and the MX-C250F at the top of your shopping list. For a start, their low power consumption and rapid warm-up times bring real savings.

They also have a special Toner Save Mode which reduces the amount of toner used for images and graphics without compromising the quality of the text. They even switch themselves off if you haven't used them for a set period of time.

5 LINE LCD OPERATION PANEL WITH PROGRAMMABLE FUNCTION KEYS



OPTIONAL 500-SHEET PAPER DRAWER

Specifications

General

| | |
|---|-----------|
| Engine speed (ppm/cpm) (Max) | |
| Colour / B/W | A4 |
| MX-C300W | 30 |
| MX-C250F | 25 |
| Paper size (Min – Max) | A6R – A4R |
| Paper weight (g/m ²) | |
| Drawer | 60 – 105 |
| Bypass | 55 – 220 |
| Optional Drawer | 60 – 105 |
| Paper capacity (Std – Max) | |
| Sheets | 300 – 800 |
| Drawers | 1 – 2 |

| | |
|-------------------------------------|--------------------|
| Warm-up time ** (seconds) | 29 |
| Memory (MB) | 512 |
| Power requirements | 220-240V, 50/60 Hz |
| Power consumption (kW) (Max) | 1.84 (200 - 240 V) |
| Dimensions (mm) (W x D x H) | |
| MX-C300W | 429 x 509 x 421 |
| MX-C250F | 429 x 509 x 398 |
| Weight (kg) | |
| MX-C300W | 29 |
| MX-C250F | 28 |

Copier

| | |
|--|---|
| Original paper size (Max) | A4 |
| First copy time ** ² (seconds) | |
| Colour | 18 |
| B/W | 10 |
| Continuous copies (Max) | 999 |
| Resolution (dpi) | |
| Scan | 600 x 600, 600 x 400 (default) |
| Print | 600 x 600 |
| Gradation levels | 256 |
| Zoom range (%) | 25 – 400 (25 – 200 using RSPF/SPF) in 1% increments |
| Preset copy ratios | 8 (4R/4E) |

Network Printer

| | |
|---------------------------|---|
| Resolution (dpi) | 600 x 600 |
| Interface | USB 2.0 10Base-T/100Base-TX |
| Supported OS | Windows® XP, Windows Server® 2003/2008/2008R2/2012, Windows Vista®, Windows® 7, Windows® 8 Mac OS X 10.4, 10.5, 10.6, 10.7, 10.8 |
| Network protocols | TCP/IP (IPv4, IPv6), IPP, Bonjour |
| Printing protocols | LPR, Raw TCP (port 9100), FTP, IPP |
| PDL emulation | PCL6, PS3 |
| Available fonts | PCL 80 PS3 136 |
| Printer utilities | Sharpdesk Mobile |

Network Scanner

| | |
|--------------------------|--|
| Scan method | Push scan (via operation panel), Pull scan (TWAIN-compliant application) |
| Resolution (dpi) | |
| Push scan | 100, 150, 200, 300, 400, 600 |
| Pull scan | 75, 100, 150, 200, 300, 400, 600 50 - 9,600 via user setting |
| File formats | TIFF, PDF, JPEG (colour only) |
| Scan destinations | Scan to e-mail, FTP server, network folder (SMB), USB memory, desktop |
| Scanner utilities | Network Scanner Tool, Sharpdesk, TWAIN, Sharpdesk Mobile |

Fax

| | |
|--|--|
| Compression method | MH/MR/MMR/JBIG |
| Communication protocol | Super G3 |
| Transmission time ** ³ (seconds) | Less than 3 |
| Modem speed (bps) | 33,600 – 2,400 with automatic fallback |
| Transmission resolution (dpi) | |
| Std | 203.2 x 97.8 |
| Fine | 203.2 x 195.6 |
| Super Fine | 203.2 x 391 |
| Recording width | A4 – A6 |
| Memory (MB) | 8 |

Wireless LAN (MX-C300W)

| | |
|-----------------------------|---------------------------------------|
| Compliant regulation | IEEE802.11n/g/b |
| Access mode | Infrastructure mode, Software AP mode |
| Security | WEP, WPA Personal, WPA2 Personal |

External Dimensions

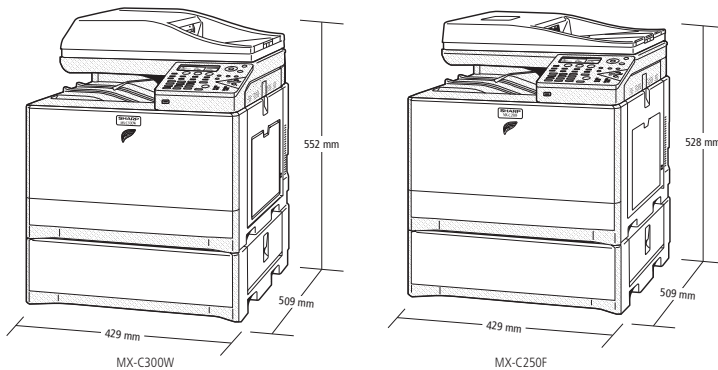

Notes

** At rated voltage. May vary depending on machine conditions and operating environment. ** Best achieved time based on A4 copy, long-edge feeding from 1st paper drawer, using glass, when machine is ready, without Auto Colour Mode and Auto Colour Selection. May vary depending on machine conditions and operating environment. ** Based on Sharp's standard chart with approx. 700 characters (A4 portrait) at standard resolution in Super G3 mode, 33,600bps, JBIG compression.

Design and specifications are subject to change without prior notice. All information was correct at time of print. The ENERGY STAR logo is a certification mark and may only be used to certify specific products that have been determined to meet the ENERGY STAR programme requirements. ENERGY STAR is a US registered mark. The ENERGY STAR guidelines apply to products only in the US, Europe, Australia, New Zealand and Japan. Windows, Windows XP, Windows Server and Windows Vista are registered trademarks of Microsoft Corporation. All other company names, product names and logos are trademarks or registered trademarks of their respective owners. ©Sharp Corporation July 2013 Ref: MX-C300W/MX-C250F. All trademarks acknowledged. E&OE. UK v1 Aug 2013.

This is Why

www.sharp.co.uk

SHARP

SHARP ELECTRONICS (UK) LTD
4 FURZEGROUND WAY
STOCKLEY PARK
UXBRIDGE
MIDDLESEX UB11 1EZ
TEL: 0800 138 5051
ROI: (+353) (0)20 8734 2000

